

PSS SHAFT SEAL SPEC SHEET

REQUIRED PART INFORMATION

Shaft Diameter (A)	Stern Tube (Shaft Log) Diameter (B)	Model of Seal
--------------------	-------------------------------------	---------------

OTHER USEFUL INFORMATION

Overall Length (Seal Envelope) (C)

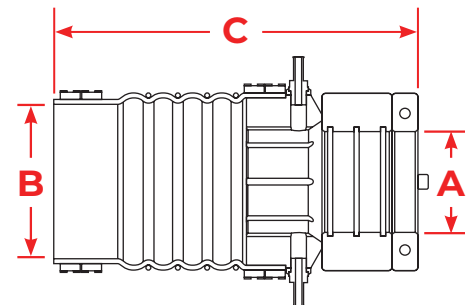
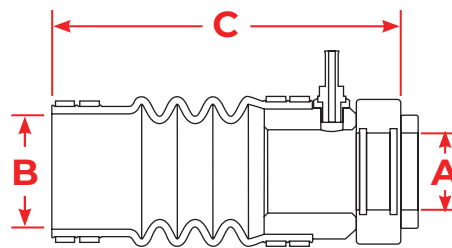
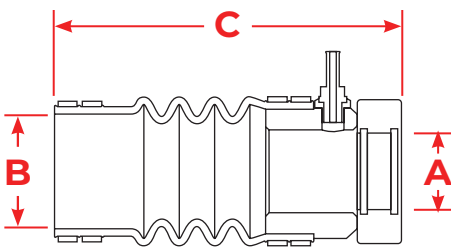

TYPE A
SHAFT SEAL

3/4" to 3 3/4" (20 to 95mm) Shafts



PRO
SHAFT SEAL

3/4" to 3 3/4" (20 to 95mm) Shafts



TYPE B
SHAFT SEAL

+4" (100mm) Shafts