

PYI, Inc.

LIMITED WARRANTY / LIMITATIONS OF REMEDIES AND LIABILITY

P.S.S. (Packless Sealing System) Shaft Seal

**Grant of Limited Warranty.** The PSS (Packless Sealing System) Shaft Seal ("PSS") is warranted by PYI, Inc. ("PYI") to the original purchaser only to be free from defects in material and workmanship under normal use and maintenance for a period of three (3) years from the date of first use or shipment, whichever comes first. During the warranty period, all original parts subject to this limited warranty and determined by PYI to be defective in materials or workmanship, will either be repaired or replaced by PYI or its authorized agent, at its sole option, free of charge, except for shipping and handling charges and dealer labor charges (if applicable), which charges are not covered by this limited warranty. The warranty on any part repaired or replaced under this limited warranty expires at the end of the original warranty period.

**Limitations of Limited Warranty.** This limited warranty does not cover and does not apply to any PSS: (i) altered in any way inconsistent with the shaft seal design as provided, (ii) improperly installed and/or maintained, (iii) incompatible with any portion or component of any boat or application that is not supplied by PYI, regardless of the cause of the failure or incompatibility of such portion or component, (iv) used for purposes other than those for which it was designed, and/or (v) subjected to misuse, neglect or accidents. In order to obtain warranty service, the PSS, together with the bill of sale or other dated proof-of-purchase document identifying the shaft seal model number, must be presented to an authorized PSS dealer during the warranty period. For assistance in locating an authorized PSS dealer, please contact PYI at: PYI, Inc.

12532 Beverly Park Road  
Lynnwood, WA 98087  
Phone: 425-355-3669

Except for the limited warranty expressly provided above, to the maximum extent permitted by applicable law, PYI and its suppliers make no warranties, express or implied, and disclaim all warranties, duties and conditions, whether express, implied or statutory, with respect to the PSS, including, without limitation, any implied warranties of merchantability, against latent defects, fitness for a particular purpose, or correspondence to description.

**Limitation of Remedies.** In the event of a breach of the limited warranty set forth above, PYI or its authorized agent will only be obligated at PYI's sole option to either repair or replace the failed PSS. If after written notice to PYI of each defect, malfunction or other failure and a reasonable number of attempts to correct the defect, malfunction or other failure and the remedy fails of its essential purpose, PYI shall refund the purchase price paid to PYI in exchange for the return of the sold good(s). Said refund shall be the maximum liability of PYI. THE FOREGOING REMEDY IS THE SOLE AND EXCLUSIVE REMEDY OF THE BUYER AGAINST PYI REGARDLESS OF THEORY, WHETHER ARISING IN CONTRACT, BREACH OF ANY WARRANTY, TORT, INCLUDING STRICT LIABILITY OR NEGLIGENCE, OR OTHERWISE.

**Limitation of Liability.** To the maximum extent permitted by applicable law, PYI and its suppliers expressly disclaim and exclude any liability for any incidental, special, indirect or consequential damages resulting from any reason whatsoever. This exclusion applies to all legal theories under which damages may be sought.

**Note:** This limited warranty gives you specific legal rights and you may also have other rights which may vary from state to state.

Please refer to the P.S.S. Shaft Seal Instruction Booklet for installation instructions.



12532 Beverly Park Road • Lynnwood, WA 98087  
Phone: (425) 355-3669 • Fax (425) 355-3661  
Email: [pyi@pyiinc.com](mailto:pyi@pyiinc.com) • Website: [www.pyiinc.com](http://www.pyiinc.com)

**P**ACKLESS  
**S**EALING  
**S**YSTEM



# SHAFT SEAL

## INSTALLATION INSTRUCTIONS

**For Shafts:**  
**3/4" to 3 3/4"**  
**(20mm to 95mm)**

## IMPORTANT INSTRUCTIONS-READ BEFORE STARTING!

**IMPORTANT! - BEFORE STARTING YOUR INSTALLATION CAREFULLY READ THE FOLLOWING WARNINGS AND INSTRUCTIONS. FAILURE TO PROPERLY FOLLOW THE WARNINGS AND INSTRUCTIONS COULD LEAD TO PERSONAL INJURY OR EVEN DEATH, OR PHYSICAL, ENVIRONMENTAL OR PROPERTY DAMAGE.**

- READ AND FOLLOW THE INSTRUCTIONS THOROUGHLY! The PSS (Packless Sealing System) Shaft Seal (“PSS”) you are preparing to install is a through-hull fitting that protects against water from entering the boat where the shaft enters the hull, when properly installed and maintained. Make sure that you or your designated installer is a qualified professional, knowledgeable and skilled to install the PSS correctly, and you have all the required tools and additional equipment on hand before beginning installation.
- Install the PSS ONLY with the boat out of the water.
- DO NOT USE oil, grease (petroleum products) or silicone products at any time during the installation. Use soap and water to lubricate the o-rings of the rotor when sliding it down the shaft.
- Clean the seal area of your boat so you do not contaminate the seal surface with dirt, oil or other foreign matter.
- Do not damage or scratch the face of the carbon or the face of the stainless steel rotor during unpacking or while handling or installing the PSS.
- There should be a total of four (4) set screws in the two holes of the rotor (2 sets screws in each hole). If you must move the stainless steel rotor, make sure to remove the top set screws in order to access the bottom two set screws.
- Do not re-use the supplied cupped pointed set screws. If multiple tightening has flattened the cupped-point set screw, replace the affected screw with a new one
- There should be a total of four (4) hose clamps securing the bellows ends. .
- Replace the nylon barb if seal runs dry.
- Do not tighten or replace the installed nylon hose barb fitting with a metallic fitting (bronze or stainless steel). Metal hose barbs will damage the carbon and destroy the PSS.
- Do not slide the aft bellow cuff too far down over the stern tube. The leading edge of the stern tube could cause damage to the inner ribs of the bellow and improperly limit the bellow movement and travel.
- If fitting a vent line (boats under 12 knots), do not run a loop at the top end of the hose as this could promote a siphon and water could enter the boat.
- If the boat sits idle for a long period of time (generally 3 months or more), it is necessary to move the carbon face back to allow a small amount of water to enter the boat.
- As with any hose under the waterline, the PSS bellows must be inspected on a regular basis (i.e., no less than at least every 6 months under most circumstances) and checked for any signs of deterioration (cracks, splits, tears, brittleness, or other signs). Upon any sign of deterioration the bellow must be replaced. As preventive maintenance the bellow should be replaced no less than every six (6) years, regardless of its apparent condition.
- Do not allow any petroleum-based liquid or corrosive material to come in contact with the PSS. Take care to ensure that this does not occur, for example, when performing any general maintenance, or winterizing the engine.
- The shaft must be near centered and parallel to the shaft log.
- Do not use an ozone generator (e.g., air cleaner) in or around your boat. The extra ozone will speed up the deterioration of any rubber product, including the PSS bellow.
- The bellows will need more frequent inspection and replacement in an environment where non-sealed batteries emit sulfuric acid vapors. Sulfuric acid vapors will accelerate deterioration of any rubber materials including the PSS bellows.
- Do not use sealant to fit the bellow to the stern tube or the hose to hose barb.
- Do not run dry.

## TROUBLESHOOTING

### A. High-pitched squeal:

If you hear a high-pitched squeal from the PSS shaft seal during operation, the seal may not be getting water. Review and correct plumbing to the seal.

**CAUTION: If the seal has run dry use caution! The faces (stainless steel rotor and carbon) may be very hot.**

### B. Spray or mist during operation after the break in period:

The dimensions provided in the “Bellow compression chart” are average figures and are provided as a guide. The EXACT compression amounts required can vary due to different types of engine mounts and water pressure being fed to the seal. If you experience any spray or mist following the break in period, make sure that the bellows had been compressed properly. If so, add an additional 14 of compression to the seal and soon the mist should disappear. Keep adjusting until the spray or mist stops.

### C. Dripping at rest:

If the PSS seal drips while at rest then it is likely that foreign material is on the face of the seal between the stainless steel rotor and the carbon flange. To clean this foreign material from the seal, insert a clean rag carefully between the two faces (Note: some water will come into the boat at this time if the boat is in the water) and work the rag around the seal. As you do this, the incoming water will flush the impurities. Remove the rag from the seal and the leak should stop.

## BREAK-IN PERIOD

On average, the PSS requires approximately one (1) hour of break in time, which allows the carbon flange to polish the mating face of the stainless steel rotor. During the break in period you will experience a very fine mist, sometimes associated with a back dust coming from the PSS. Under normal conditions, this will stop after an average of one (1) hour running time.

*Copyright © 2005 PYI, Inc. All rights are reserved. No part of this document may be reproduced, transmitted, transcribed, stored in a retrieval system, or translated into any language or computer language, in any form or by any means, without the prior written permission of PYI, Inc.*

*PYI, Inc. makes no representations or warranties, express or implied, with respect to this document or the contents herein and specifically disclaims any implied warranties of merchantability or fitness for any particular purpose. In addition, PYI, Inc. reserves the right to revise this document and to make changes from time to time in the content hereof.*

For high-speed vessels it is required that a water supply be plumbed to the PSS for the purpose of cooling and lubricating the seal faces (i.e., at over approximately 12 knots of speed a vacuum is created in the stern tube and water is drawn away from the PSS resulting in a loss of cooling water that may cause the carbon to over heat). There are multiple sources of water for this supply. The following are a few non-exhaustive examples. These are examples only and they may or may not apply to your particular boat.

- T-off the engine raw water-cooling line. (Note: T-kits are available separately from PYI, Inc for internal hose 3/4", 1", 1 1/4", 1 1/2").

- Thread a barb fitting into the drain plug of the heat exchanger if applicable.

- Thread a barb fitting into the drain plug of the exhaust manifold if the manifold is raw water-cooled.

- Add a small scoop under water for keel-cooled boats or t-off another water pick-up. (Note: A valve must be installed to regulate the water flow as too high a water flow may over pressurize the PSS seal). Use an appropriate "underwater rated" hose from the fittings on the boat and the fitting on the PSS and secure them with two (2) hose clamps at each end.

**NOTICE:** All plumbing must follow the standards and practices of proper boat plumbing. For example, if the pick-up on the engine is located under the waterline, an anti-siphon fitting must be installed, in addition to other standards and practices.

- Pick-up points at the bottom of elbows may fill with sand or debris if the vessel operates in shallow water or runs aground. These should be inspected regularly.
- Some pick-up points may be "dry" locations. It is important to check for adequate water flow before operating the vessel.
- There should be a little slack left in the hose at the shaft seal end to allow for some movement and to eliminate "loading" of the shaft seal on the shaft.
- Before operating the vessel, check to make certain that the pick-up system delivers water at idle. We assume that water flow at idle increases with throttle. Good flow at idle is even better at speed.
- Manifold pick-up points will have to be inspected regularly to eliminate rust and scale from around fitting.

16. Testing: When launching the boat, inspect the PSS and make sure the PSS is properly in place. Water should not be entering the boat from the PSS seal area. Run the engine in gear as in a normal operation. It is normal at this time to notice a very fine spray or mist coming from the seal and some carbon dust, as the PSS requires a break in period (see below). The PSS should not be leaking at rest and should never spray more than just a fine spray or mist.

## INSTALLATION INSTRUCTIONS

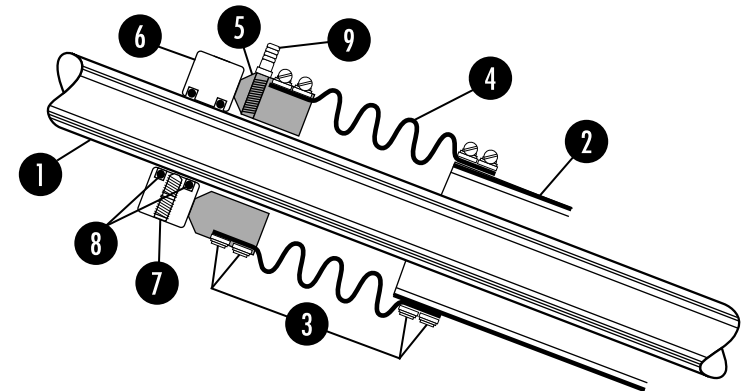

- |  |  |
|--|--|
| <b>1</b> Propeller Shaft                 | <b>7</b> Stainless Steel Set Screws (5 total/<br>4 for rotor, 1 spare) |
| <b>2</b> Shaft Log (Stern Tube)          | <b>8</b> Nitrile O-Rings (2 in rotor/2 spare)                          |
| <b>3</b> Stainless Steel Hose Clamps (4) | <b>9</b> Nylon Hose Barb Fitting                                       |
| <b>4</b> Nitrile Bellow (1)              | <b>10</b> Clamp Protectors (4)   |
| <b>5</b> Carbon Graphite Flange (1)      |  |
| <b>6</b> Stainless Steel Rotor (1)       |  |

IN ALL CASES, THE BOAT MUST BE OUT OF THE WATER TO PERFORM THIS INSTALLATION.

1. Unbolt the shaft coupling from the transmission coupling.
2. Remove the shaft coupling from the shaft. Coupling styles will vary by manufacturer. Some couplings use set screws to keep the coupling in place, while others use a roll pin and others use a nut (always use the appropriate tools and procedures for your particular application).
3. Remove the old stuffing box and packing material. There are three types of packing glands that can be found on most boats: "Classic", "Bolt On" and "Threaded".
4. Clean the entire exposed portion of the shaft with very fine sand paper (# 400 or # 600 grit) in order to remove any debris or rough edges. Pay particular attention to the keyway located at the forward end of the shaft, where the stainless steel rotor will pass. The shaft and keyway must NOT have any sharp edges that could damage the o-rings upon installation.

5. Slide the open end of the bellow and its hose clamps down the shaft and onto the bare stern tube and make sure the bellow has a proper fit over the shaft log. Once in place the bellow should overlap the stern tube by the same amount as the bellow cuff so the hose clamps will properly tighten the bellow to the shaft log. **WARNING:** Do not slide the bellow cuff too far down and over the stern tube. If the bellow is slid too far onto the stern tube the forward edge of the stern tube could damage the inner ribs of the bellow and improperly limit the bellow's travel. Tighten the hose clamps to secure the bellow to the stern tube and fit the red clamp protector to the tail of the hose clamps.

6. Make sure the carbon flange is in place on the forward end of the bellow and that the two hose clamps properly secure it. Also confirm that the carbon is free of any defects or imperfections on its polished face.

7. Remove the stainless steel rotor from the protective pouch. Verify that there are two (2) o-rings placed into the o-ring grooves inside the bore of the rotor. Confirm that the mating face of the rotor is free of any defects or imperfections. Take two (2) (Two Only) of the set screws from the plastic bag and thread them into the rotor holes. Save the remaining set screws for use later during installation. Thread one screw into each hole, stopping just short of the screw protruding into the inside bore of the rotor.

8. Lubricate the shaft and o-rings of the rotor, and slide the stainless steel rotor down the shaft. Use a petroleum free liquid (e.g., a dish soap / water solution works well) as the lubricant. Caution: **DO NOT USE OIL, GREASE OR SILICONE AS THE LUBRICANT.**

9. Re-attach the shaft coupling to the shaft and make sure that all the safety devices provided and recommended by the coupling manufacturer are in place.

10. Re-attach the shaft coupling to the transmission making sure that it is installed to the manufacturer specifications and tolerances. Make sure all the safety devices provided and recommended by the coupling manufacturer are in place.

11. Now that the shaft is in place, verify that the carbon is centered on the shaft (note the carbon ring is bored at a larger diameter than the shaft), verify that the bellow cuff is properly placed on the stern tube and verify that the shaft is near center in the shaft log. Adjust accordingly. Tighten all the hose clamps around the stern tube and the carbon.

## **BELLOW COMPRESSION CHART**

<b>Shaft Diameter</b>	<b>Compression Amount</b>
<b>3/4" to 1 1/8" (20mm-30mm)</b>	<b>3/4" (20mm)</b>
<b>1 1/4" to 2" (32mm to 55mm)</b>	<b>1" (25mm)</b>
<b>2 1/4" to 3 3/4" (60mm to 95mm)</b>	<b>1 1/4" (32mm)</b>

12. Slide the stainless steel rotor down the shaft until it just **TOUCHES** the carbon. Mark this position on the shaft as the "neutral" position with a marker or a piece of tape on the shaft just in front of the rotor.

13. Sliding the stainless steel rotor aft, compress the bellow by the amount indicated on the bellow compression chart, using the "neutral" mark as a reference point. While keeping the bellow in the "compressed" position, tighten the two (2) set screws against the shaft with the provided allen wrench (Use approximately 6 foot pounds of torque for shafts 3/4" to 1 3/8" and 8 foot pounds of torque for shafts 1 1/2" to 3 3/4". If you need to insert the long arm of the allen wrench into the hole, a vice-grip, for example, may be fitted on the short arm to help provide the required torque.

14. Remove from the plastic bag two (2) additional set screws, and thread one into each hole and tighten them against the first set screws. This will act as a locking device for the first set screws.

15. Plumbing the system:

Note: Sailboats or displacement powerboats with a powering speed below 12 knots can use either method A or B. However, displacement boats with a bearing in the shaft log must plumb water to the seal.

15A. Low speed boats: (Under 12 knots of boat speed under power and no bearing in the shaft log).

Using a 3/8" (8 or 9 mm) ID "underwater rated" hose (not provided with the PSS), connect the hose to the hose barb fitting installed on the carbon and secure the hose with two (2) hose clamps. Run the hose to a point in the boat at least two (2) feet above the waterline, making sure that the hose does not apply any load on the carbon part of the seal. Keep the hose as close as possible to the centerline of the vessel so the top of the vent hose is never below the waterline, even if the boat heels. Secure the hose in place with the necessary fittings that insure it will not pull free and drop. This hose is now a venting hose that will help ensure that no air is trapped in the seal.

**WARNINGS:** Do not run a loop at the top end of the vent hose as it could start a siphon action in some extreme conditions. Also, make sure the vent hose is properly secured from falling below the waterline. If the vent hose were to fall down below the waterline, water would come in the boat. Also, do not plug or block the end of the vent hose, as this would prevent the line from venting.

15B. High-speed boats: (Over 12 knots of boat speed under power).

Note: Boats that can exceed 12 knots on a single engine must run a crossover line between seals to ensure both seals maintain water flow.